



QuComm IST-1999-10033

Long Distance Photonic Quantum Communication

QuComm Deliverable D18

Dissemination level: Public

DELIVERABLE D18 (REPORT)

High fidelity quantum teleportation

Prepared by

Gregor Weihs, Thomas Jennewein, and Anton Zeilinger
EXPUNIVIE

Wolfgang Tittel, Hugo Zbinden and Nicolas Gisin
GAP Optique

ABSTRACT

After quantum teleportation has been demonstrated for the first time in 1997 a discussion has been going on about potential measures and criteria for the performance of the various experimental teleportation schemes. One particular criterion is the fidelity or overlap between corresponding input and output states. If the fidelity was ideal every allowed input state would be teleported perfectly. Any real piece of apparatus is clearly far from ideal. Here we report on the activities to push the fidelity closer to ideal, which recently lead to the striking demonstration of a violation of Bell's inequality for teleported entanglement.

Report Version: 1

Report Preparation Date: 2001-06-29

Classification: Public



**Project funded by the European Community
under the "Information Society Technologies"
Programme (1998-2002)**

INTRODUCTION

Quantum teleportation [BBC+93] is a means to communicate quantum information independent of the physical realization of the very qubit that we want to send. Quantum teleportation crucially depends on two components: entanglement and Bell-state analysis. Entanglement is the quantum physical notion that describes inseparable states of separate systems. Bell-state analysis refers to the ability to analyse the state of two particles in a basis of entangled states.

Originally there were three experiments which claimed to realize quantum teleportation two of which [BPM+97, FSB+98] performed quantum teleportation of an unknown quantum states, whereas the third one [BBDM+98] is nowadays known as “remote state preparation.” Soon afterwards the question arose with what kind of procedure one should assess the capabilities of a certain teleportation machine. From that discussion two criteria, fidelity and efficiency emerged.

The measure called fidelity is the overlap between the input and output states. If it is equal to one, then the teleportation apparatus teleports the input state perfectly. If it is one half only, the corresponding machine will produce random results. The following table shows a few important fidelity thresholds:¹

	Random guessing	Measurement and class. communication	Violation of Bell’s inequality	Perfect, error free operation
Fidelity	0.5	0.67	0.85	1

The fidelity is distinct from the efficiency of a teleportation machine, which measures the fraction of the cases in which the machine works at all. Fidelity, in contrast, measures the quality of the output provided that the teleportation machine worked. Also, as can be seen in the above table, the fidelity measures whether one could simulate the behaviour of a certain teleportation apparatus by classical means or not.

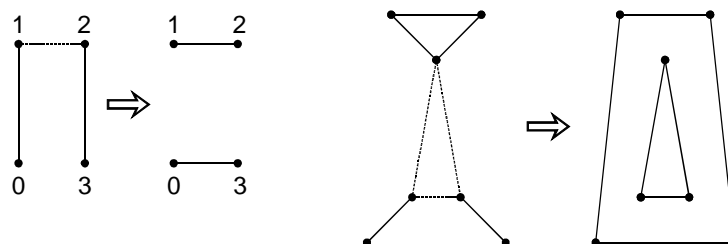

Figure 1: Entanglement swapping in the most basic case (left) and in a generalized case. The dashed lines represent entangled state projection measurements, whereas the solid lines mean the presence of entanglement between the connected dots.

The most important threshold can be established by linking teleportation to the concept of entanglement swapping [ZZHE93, BVK98], which is – in a very basic case – the teleportation

¹ Values below on half indicate that the teleportation apparatus produces the complement of an input state; so a value of 0 indicates perfect anti-teleportation, which is actually impossible [BHW99].

of particles that are entangled with other particles before the operation. In this case, even though the Hilbert space that is teleported is only part of the total Hilbert space, in a proper teleportation apparatus the coherence with the other parts must be retained.

The left part of Fig. 1 gives us the possibility to directly measure the fidelity of a teleportation apparatus. In the diagram, particle 2 can be thought of as being teleported onto particle 4. Consequently the entanglement between 1 and 2 is transferred to entanglement between 1 and 4. The quality of the final entanglement between 1 and 4 as compared to the quality of the initial entanglement between 1 and 2 is just the fidelity.

The most important limit for the quality of entanglement is established by Bell's inequality. It provides a boundary between potentially classical and proven nonclassical behaviour. Once a correlation measurement breaks this limit it cannot be explained by a local realistic theory. Because of this close link between teleportation and entanglement swapping we will use both terms in the following to describe our work. The connection is further illustrated by Fig. 2. Here, Victor, the verifier, is the instance that checks Alice and Bob's apparatus.

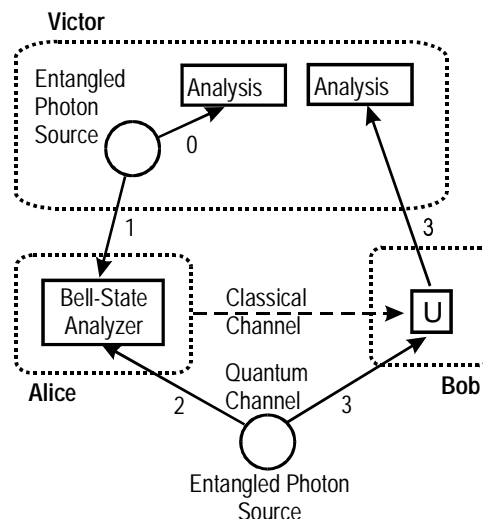

Figure 2 Alice and Bob run a teleportation link. Victor verifies that link by handing particle 1 to Alice and checking the final entanglement between particles 0 and 3 after teleportation has completed.

EXTENDING QUANTUM TELEPORTATION TO OTHER QUBIT REALIZATIONS

Within QuComm high-fidelity teleportation is pursued in WP4. WP4.1 on the one hand tries to push the fidelity over the Bell inequality limit and on the other hand to transfer the expertise that has been gained for polarization qubit realizations (EXPUNIVIE, LMU) to the domain of time-bin entangled qubits in the telecom wavelength region (GAP). GAP is currently implementing teleportation for time-bin qubits. Fig. 3 shows a schematic of the experiment that GAP has set up. These sources meanwhile reached the critical fidelity of 71%.

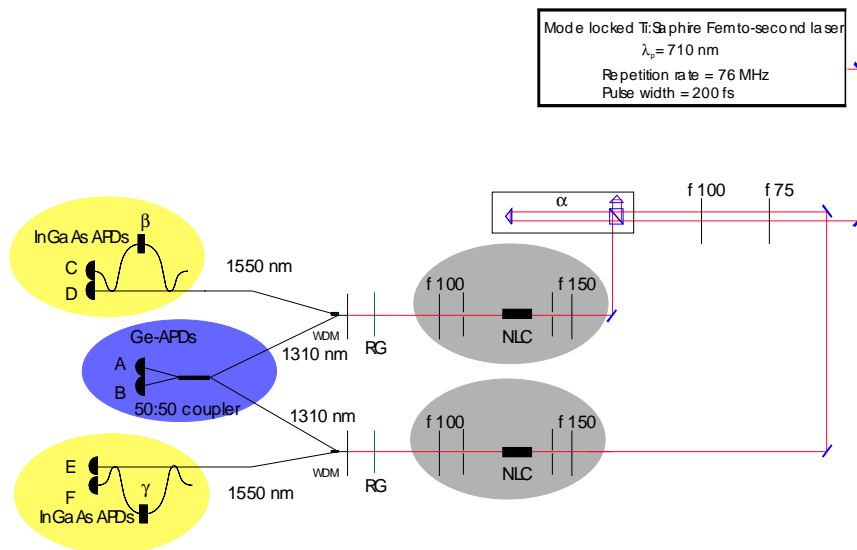

Figure 3 A short pulse emitted by a Ti:Sapphire fs laser is split into two subsequent pulses by means of a folded Mach-Zehnder Interferometer. Each output then pumps a non-linear crystal (NLC), generating time bin entangled qubits at wavelengths of 1310 and 1550 nm, respectively. The photons forming a pair are separated using a wavelength demultiplexer (WDM), and the two lower wavelength photons are subjected to Bell measurement by means of a 50:50 fibre coupler. To confirm that the two 1550 nm photons indeed get entangled, they are subjected to a Franson-type test of Bell inequalities using two equally balanced Mach-Zehnder Interferometers.

PUSHING THE FIDELITY LIMIT

As said in the introduction, one of the central goals in the teleportation research is to push the fidelity over the Bell inequality limit of 85%. Historically this limit could not be surpassed [BPM+97, PBWZ98] mainly due to limitations in the ability to perform unambiguous Bell-state analysis (BSA). BSA is treated within QuComm in WP2. The work that was done within WP2 was naturally strongly interconnected with WP4. The findings presented in the report on complete Bell-state characterisation (D14) finally led to reaching milestone M19 with a slight delay in actually producing all the necessary numerical results needed to violate Bell's inequality for teleported entanglement. These results and the methods by which they were achieved will be described in the following pages. A publication has been submitted [JPWZ01].

FIBER BASED BELL-STATE ANALYSIS

For all subsequent considerations we have in mind a set-up as shown in Fig. 4 which is realized for entangled photon pairs produced in parametric down-conversion.

From the previous experiments that tried to teleportation it was clear that it would be difficult to perform Bell-state analysis for independently created particles at high visibility levels. There are various reasons that can reduce the fidelity. Bell-state analysis with linear optical elements is based on Hong-Ou-Mandel interferometry [HOM87]. Just as in any other

interferometer it is the mutual coherence of the interfering processes – or the indistinguishability – that governs the achievable visibility apart from imperfection of the components and the like. In our case one wants to interfere photons that are components of two independently created pairs.

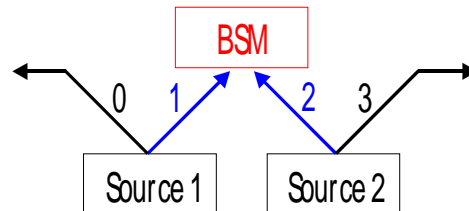

Figure 4 Schematic of the entanglement swapping or teleportation of entanglement experiment. Two pairs of particles are created in sources 1 and 2. Particle 1 is teleported over to particle 3, whereby the entanglement between particles 0 and 1 is transferred to entanglement between particles 0 and 3. The Bell-state measurement (BSM) is a projective measurement in an entangled state (Bell-) basis. In our photonic case the BSM is done interferometrically.

Pairs are created by spontaneous parametric down-conversion (SPDC). In their creation process the photons suffer from all the dispersion effect that can occur in the conversion crystal. For reasons that will be explained below it is necessary that pulsed lasers are used to pump the SPDC. With pulsed lasers however not only phase but also group dispersion effects have to be considered. This means that for a certain pulse width and a certain conversion crystal size the achievable visibility is limited.



Figure 5 Fiber Bell-state analyzer realized by EXPUNIVIE for High-fidelity teleportation

Coherence of the independent photons is created by spectral filtering that extends their mutual coherence time to a value longer than the uncertainty of their creation time. Therefore femtosecond pulsed lasers are required in order to be able to reach reasonable count rates. The filtering makes the independently created photons indistinguishable and the interferometric BSA can work. It turned out, that for photons from parametric down-conversion sources the selection of the radiation that is emitted by the crystal plays a crucial role in establishing this coherence (because it acts as a spectral filter) and also for the quality of the initial entanglement. One can optimally select from the crystal a single spatial mode by coupling the

light into a single-mode optical fibre. Therefore it seems natural to first couple into the fibre and then do the Bell-state analysis.

These considerations led to the construction of a fibre Bell-state analyser (s. Fig. 5) that was already described in D14. Here we want to show its application to the case of teleportation. Because fibre coupling is very sensitive to the incoming beam's mode and direction an active stabilization scheme had to be developed to allow continuous measurements of more than a day. Previously, drift and fluctuations in the pump lasers deteriorated the beam alignment over time and therefore limited the achievable measurement duration.

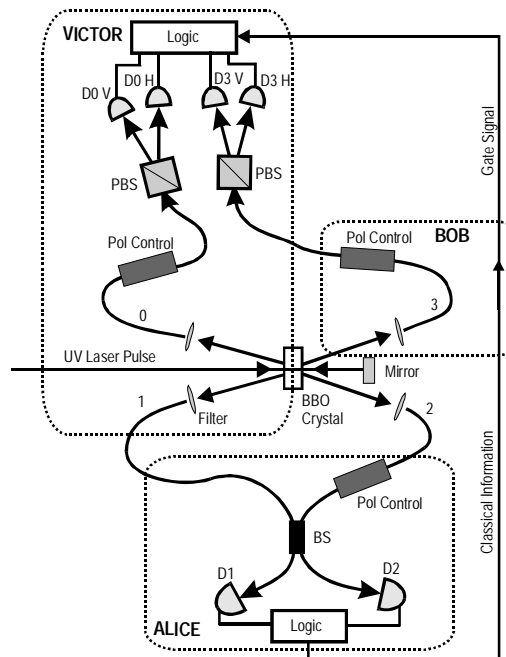

Figure 6 Schematic of the high-fidelity teleportation experiment.

The fibre BSA was embedded into a schematic that is shown in Fig. 6. The use of fibres made polarization control necessary in every arm. Victor's outputs (photon 0 and 3) for which Bell's inequality would be tested were equipped with two detectors each, in order to be able to measure all probabilities for a certain combination of analyser settings at once. This, in combination with the above mentioned beam control facilities allowed to really measure all necessary numbers for a violation of Bell's inequality.

BELL'S INEQUALITY

Bell's inequality [Bel64] is a statement about possible correlations in predictions of local realistic theories. As quantum physics predicts very strong nonlocal correlations for entangled systems Bell's inequality allows to decide experimentally whether quantum physics or local realism is ruling nature. Up to now nearly all experiments were in favour of quantum physics.



Figure 7 Photograph of the high-fidelity teleportation or entanglement-swapping experiment. In the foreground one can see Victor's polarization measurement, in the middle Alice's Bell-state analyser rests in an elevated box above the table. The contains the frequency doubled Ti:Sapphire pump laser.

With the advent of quantum information Bell's inequality, previously being of mostly philosophical interest, became a tool for the quantification of quantum behaviour and separability. Therefore it is now omnipresent in quantum information physics, although its role in comparison with other measures is not completely clear [HHH96].

A widely used form is the CHSH form [CHSH69] that states that the so-called Bell parameter

$$S = |E(a,b) - E(a,b')| + |E(a',b) + E(a',b')|$$

should always have a value less than 2 for local realistic theories. Quantum physics, however, predicts a value of $2\sqrt{2}$ for suitably chosen measurements on a maximally entangled two-particle system. The quantity $E(a,b)$ is the correlation of a polarization measurement in direction a on one particle and in direction b on the other one, where the individual measurements can take place arbitrarily far apart.

RESULTS

A photograph of the set-up is shown in Fig. 7. The following table summarizes the experimental correlation data $E(a,b)$ as measured for particles 0 and 3:

	0°	45°
22.5°	-0.628 ± 0.046	-0.541 ± 0.045
67.5°	$+0.677 \pm 0.042$	-0.575 ± 0.047

These numbers lead to $S = 2.421 \pm 0.091$ which is more than four standard deviations above the local realistic limit.

The asymmetry among the correlation values is explained in Fig. 8, which shows the dependence of the experimental correlation for parallel analysers as a function of the angle. The reason why it is not constant – as it should be in the ideal case – is that some dispersion effects do not contribute to errors in the horizontal-vertical basis but only in the complementary basis. This is again due to the fact that the crystals in which the pairs are produced are producing them originally as horizontally and vertically polarized photons and only (necessarily imperfect) compensation techniques render these two cases indistinguishable.

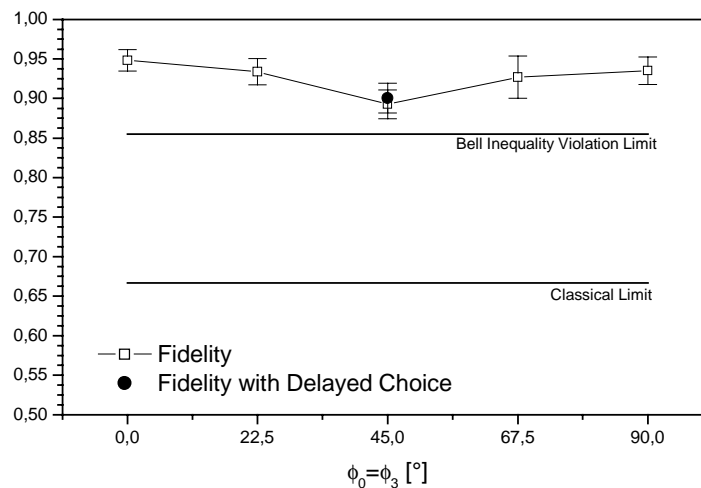

Figure 8 Fidelity as a function of absolute analyser angle (parallel on both sides, referenced on vertical) of the high-fidelity teleportation experiment. The classical and local realistic (Bell) limits are given for comparison. The fidelity at 45° is slightly less than at 0° and 90° . Delaying the BSA until long after the polarisation correlation measurement does not have any influence (Delayed Choice).

OUTLOOK

Entanglement swapping is an important procedure in quantum information because it not only allows us to check teleportation but also it can be used to enhance entanglement links via quantum repeater protocols [BDCZ98] and it is at the heart of purification of entangled states. Therefore the work within QuComm has to be extended in three directions. First, we will try to transfer the knowledge to other technical areas and to different degrees of freedom of photons. Second, we will try to still increase the fidelity level, and third we want (WP4.2) to increase the efficiency which is notoriously low.

On the one hand there are technical reasons why the efficiencies are not ideal. This is for example the lack of perfect detectors and of deterministic pair sources. On the other hand there is the theorem that with linear optical elements a perfect BSA can not be built [CaL01]. However, Knill *et al.* [KLM00], by giving a nice example have shown explicitly that this does



not prohibit scalability, and it is believed that indeed small quantum computer could be built with linear optical elements only.

REFERENCES

- [BBC+93] Charles H. Bennett, Gilles Brassard, Claude Crépeau, Richard Jozsa, Asher Peres, and William K. Wootters, *Teleporting an un-known quantum state via dual classical and Einstein-Podolsky-Rosen channels*, Phys. Rev. Lett. **70** (1993), no. 13, 1895–1899.
- [BBDM+98] D. Boschi, S. Branca, F. De-Martini, L. Hardy, and S. Popescu, *Experimental realization of teleporting an unknown pure quantum state via dual classical and Einstein-Podolsky-Rosen channels*, Phys. Rev. Lett. **80** (1998), 1121–1125.
- [BDCZ98] H.-J. Briegel, W. Dür, J. I. Cirac, and P. Zoller, *Quantum repeaters: The role of imperfect local operations in quantum communication*, Phys. Rev. Lett. **81** (1998), 5932–5935.
- [Bel64] J.S. Bell, *On the Einstein Podolsky Rosen paradox*, Physics **1** (1964), 195–200.
- [BHW99] V. Bužek, M. Hillery, and R. F. Werner, *Optimal manipulations with qubits: Universal-NOT gate*, Phys. Rev. A **60** (1999), R2626–R2629.
- [BPM+97] D. Bouwmeester, J.-W. Pan, K. Mattle, M. Eibl, H. Weinfurter, and A. Zeilinger, *Experimental quantum teleportation*, Nature **390** (1997), 575–579.
- [BVK98] S. Bose, V. Vedral, and P. L. Knight, *Multiparticle generalization of entanglement swapping*, Phys. Rev. A **57** (1998), 822–829.
- [CaL01] J. Calsamiglia and N. Lütkenhaus, *Maximum Efficiency of a Linear-Optical Bell-State Analyzer*, Applied Physics B **72** (2001) 67–71.
- [CHSH69] J. F. Clauser, M. A. Horne, A. Shimony, and R. A. Holt, *Proposed experiment to test local hidden-variable theories*, Phys. Rev. Lett. **23** (1969), 880–884.
- [FSB+98] A. Furusawa, J. L. Sorensen, S. L. Braunstein, C. A. Fuchs, H. J. Kimble, and E. S. Polzik, *Unconditional quantum teleportation*, Science **282** (1998), 706–709.
- [HHH96] R. Horodecki, M. Horodecki, and P. Horodecki, *Teleportation, Bell’s inequalities and inseparability*, Phys. Lett. A **222** (1996), 21–25.
- [HOM87] C.K.Hong, Z.Y.Ou, and L.Mandel, *Measurement of subpicosecond time intervals between two photons by interference*, Phys. Rev. Lett. **59** (1987), no. 18, 2044.
- [JPWZ01] T. Jennewein, J.-W. Pan, G. Weihs, and A. Zeilinger, *High-fidelity quantum teleportation*, to be published, 2001.
- [KLM00] E. Knill, R. Laflamme, and G. Milburn, *A Scheme for Efficient Quantum Computation with Linear Optics*, Nature **409** (2001), 46–52.
- [PBWZ98] Jian-Wei Pan, Dik Bouwmeester, Harald Weinfurter, and Anton Zeilinger, *Experimental entanglement swapping: Entangling photons that never interacted*, Phys. Rev. Lett. **80** (1998), 3891–3894.
- [ZZHE93] M. Zukowski, A. Zeilinger, M. A. Horne, and A. K. Ekert, “Event-ready-detectors” Bell experiment via entanglement swapping, Phys. Rev. Lett. **71** (1993), no. 26, 4287–4290.